

SUPERYACHT TENDER FENDERS

MAXIMUM PROTECTION FOR YOUR TENDERS

After an extensive design phase with lengthy consultation from yacht captains and deck crew, C-Quip International has developed a new range of carbon fibre tender fender products to suit any yacht and any tender. These new products complement C-Quip's extensive range of boarding and tender handling equipment.

Whilst every yacht will require some customisation of these designs to suit the transom profile, the choice of product will depend on the tender type and weight.

- **The T-10 is for large tenders up to 10,000kgs**
- **The T-5 is for tenders up to 5,000kgs**
- **Fully customised tender fenders are available for yachts with unique requirements**

Each of the tender fender frames is made from pre-preg carbon fibre which has been optimised with the help of extensive computer simulation to achieve maximum rigidity at the minimum weight.

The fenders can be locked in place using either the yacht's existing sockets or custom designed units.

All frame designs have a molded hand-hold on the top and the bottom to make handling of these large items much easier for the crew.



T-10



CUSTOM
TENDER FENDER

SUPERYACHT TENDER FENDERS

PASSERELLES

BOARDING STAIRS

CRANES/DAVITS

LIGHTMASTS

BOAT BOOMS

TENDER FENDERS

SWIM LADDERS/STAIRS

T-5 / T10

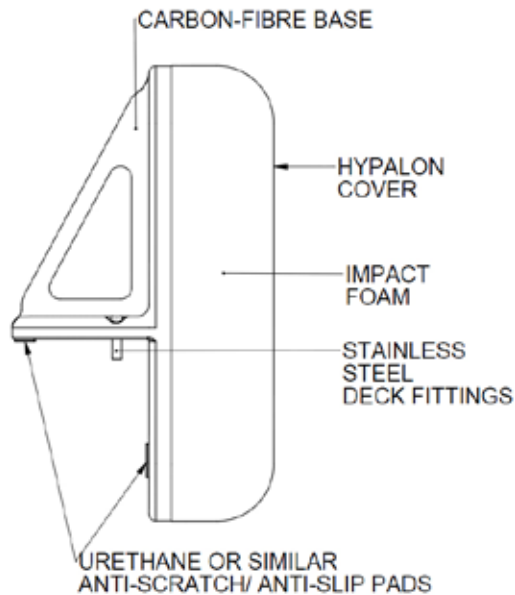

CUSTOM

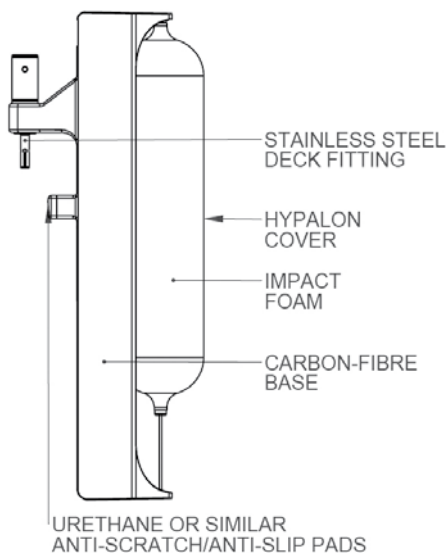

C-QUIP TENDER FENDER

- Intelligent design – maximum management of impact loads
- Maximum protection for the tender, passengers and crew
- Light-weight, strong and durable construction
- Easy handling by crew
- Clear coat carbon fibre or yacht colour scheme
- Fender available in eight colours
- Customised to the yacht transom profile



TECHNICAL INFORMATION

CONSTRUCTION

T-5

Fender Style:	Fixed – rigid foam
Length:	2000mm
Width:	350 mm
Weight:	20kg
Tender Weight:	< 5 tonnes
Available Finish:	Clear coat carbon fibre or yacht colour scheme
Fender Colour:	Available in a variety of colours
Deck Fittings:	Highly polished 316 stainless steel

T-10

Fender Style:	Fixed – rigid foam
Length:	2000mm
Width:	350 mm
Weight:	25kg
Tender Weight:	< 10 tonnes
Available Finish:	Clear coat carbon fibre or yacht colour scheme
Fender Colour:	Available in a variety of colours
Deck Fittings:	Highly polished 316 stainless steel

CUSTOM

Fender Style:	Rotating – rigid foam
Length*:	1700mm
Width:	320mm
Weight:	22kg
Tender Weight:	< 3 ton
Available Finish:	Clear coat carbon fibre or yacht colour scheme
Fender Colour:	Available in a variety of colours
Deck Fittings:	Highly polished 316 stainless steel

**The length is an indication only and can be customised to suit each yacht.*