

## TENDER GARAGE CRANES

C-Quip's Overhead Cranes can be manufactured in carbon fibre, stainless steel or aluminium. Most often a combination of materials are used to make the lightest and strongest products available.

Utilising single or double booms, the cranes can extend out from the stern lazarette or be transversely mounted within a tender garage or beach club. Where the tender garage has port and starboard access, the beam cranes can be designed to operate on either side.

Fully integrated, sophisticated control systems make operation easier and safer for crew. The combination of synchronisation between beams and programmable tender pick-up positions ensure faster and smoother operation with less potential for damage to tenders and equipment.

- **Dual purpose cargo and rescue (M.O.B.) options**
- **Available in clear coat carbon fibre finish or yacht colour scheme**
- **All stainless steel fittings are highly polished**
- **Every crane is tested and pre commissioned in our workshop prior to delivery**
- **We have technicians who can work with you on the installation and our after sales support is backed by service engineers worldwide**
- **24 months warranty from date of commissioning**

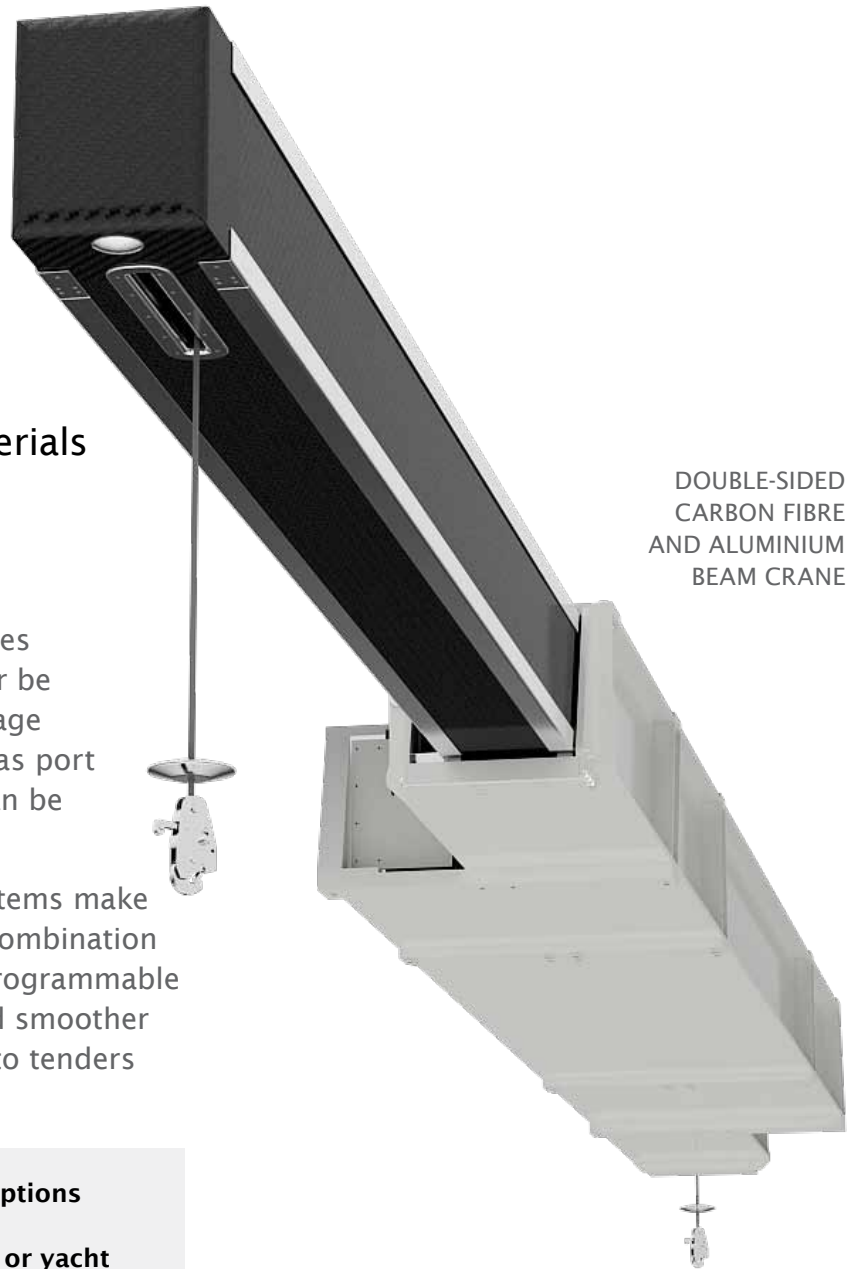

DOUBLE-SIDED  
CARBON FIBRE  
AND ALUMINIUM  
BEAM CRANE



UNDER DECK CRANE

# TENDER GARAGE CRANES

PASSERELLES

BOARDING STAIRS

CRANES/DAVITS

LIGHTMASTS

BOAT BOOMS

TENDER FENDERS

SWIM LADDERS/STAIRS



DOUBLE-SIDED BEAM  
CRANE WITH TROLLEY



TELESCOPING  
2-STAGE BEAM CRANE



## TECHNICAL INFORMATION

### CONSTRUCTION

- Weight capacity 100kg to 10 tonnes
- Single or double boom options
- Sliding trolley option for multiple tender pick-up positions
- Your choice of carbon fibre, aluminium and/or stainless steel construction
- Finest stainless steel hydraulic components
- Custom built to any length

### FULLY INTEGRATED SOPHISTICATED CONTROL SYSTEMS

- Programmable tender positions
- Fully wireless proportional remote controls including full safety features
- Can be operated from ships emergency power supplies
- Complete proportional hydraulic valve system with over load protection
- Double booms offer synchronised lift for faster and safer operation
- Fully integrated with ships alarm systems
- Touch screen controls and auto fault analysis